

## Universal Peshelf Mounting Instructions

---

Adhesive • Magnetic • VIP • Wall

## Adhesive Mounted Penshelf Front or Back Mount for Frameless Glassboards

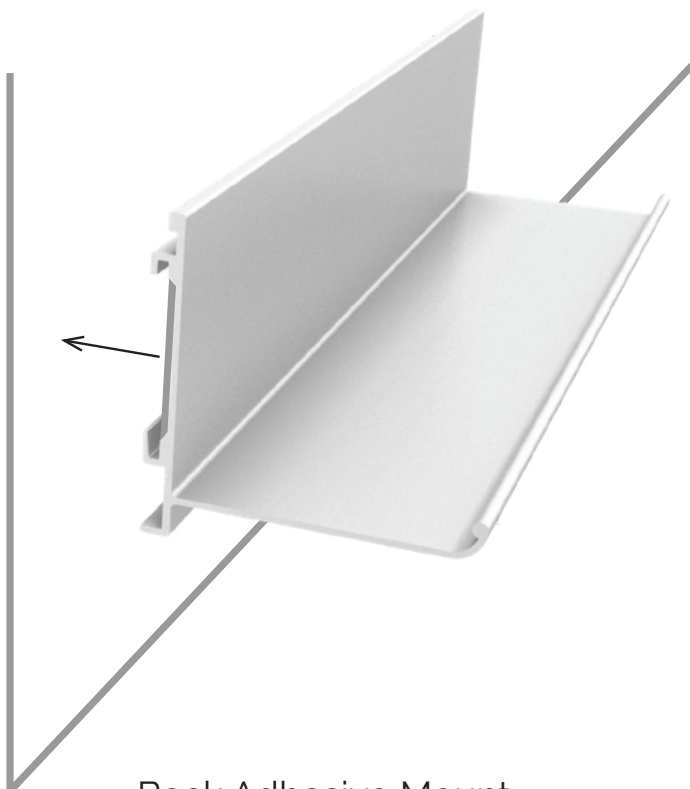

Back Adhesive Mount

**Note: Adhesive Bond is Permanent!**

Clean glass surface  
Place penshelf in desired location  
Remove adhesive covering film  
Press to glassboard

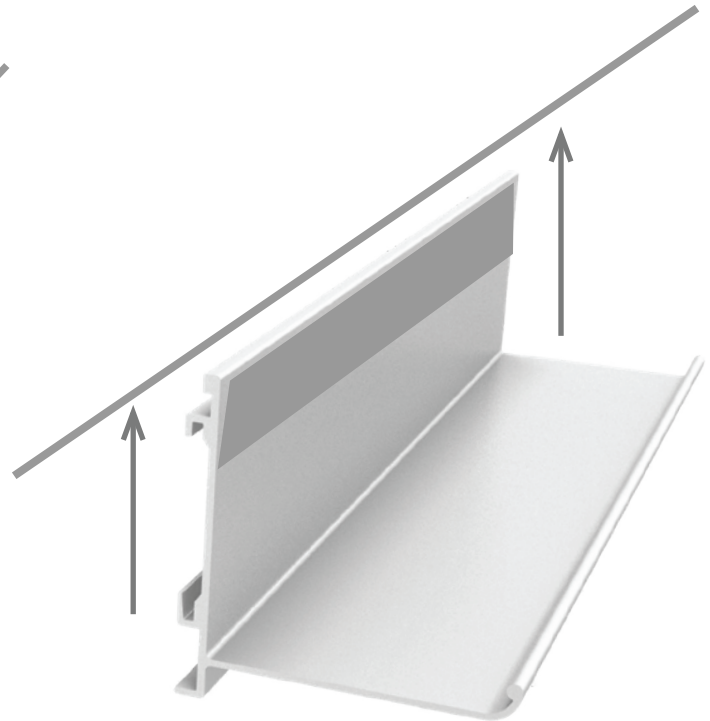

Front Adhesive Mount\*

**Note: Adhesive Bond is Permanent!**

Clean back surface of glassboard  
Place penshelf in desired location  
Remove adhesive covering film  
Insert penshelf behind glassboard  
Press to glassboard

\*Install prior to mounting glass on wall,  
if possible

## Magnetic Mounted Penshelf Glassboards or Porcelain (Markerboards/Chalkboards)

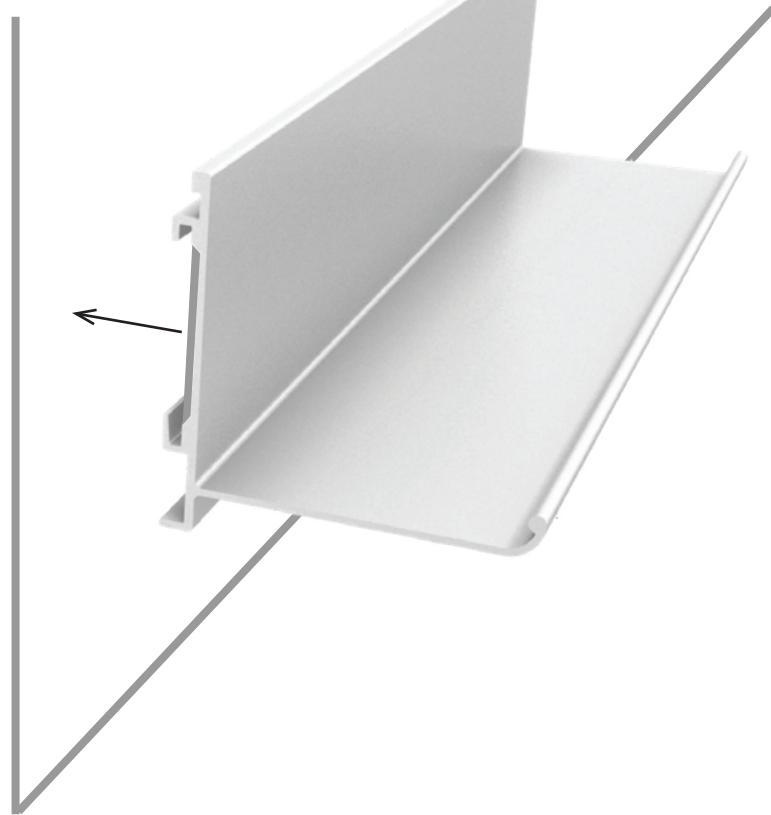

Remove protective film from "Grip Tape".  
Place penshelf in desired location  
Press to glass or porcelain board

### Items included with penshelf

Appropriate magnets for glass or porcelain included in penshelf rear track according to penshelf length.

VIP Penshelf—Anodized Aluminum  
Glassboard • Markerboard • Noticeboard • Chalkboard

Number of mounts per shelf

1 mount per 50 cm/19.5"

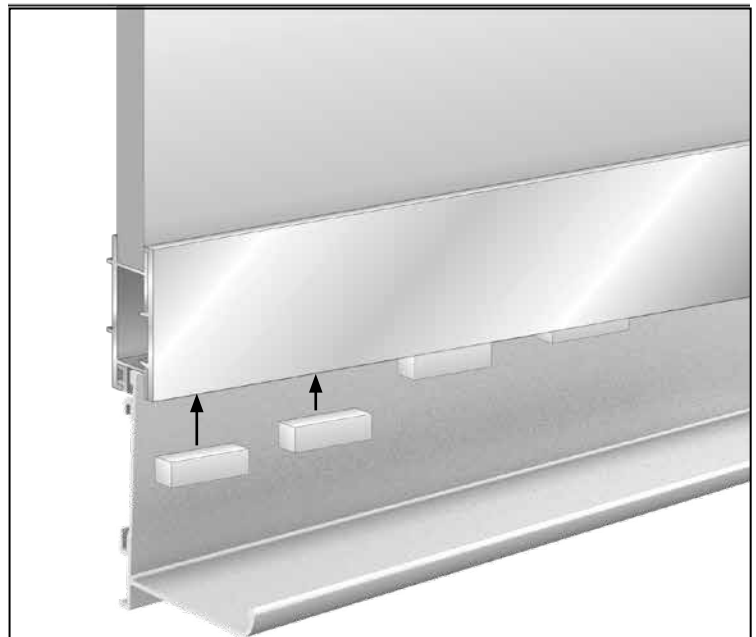
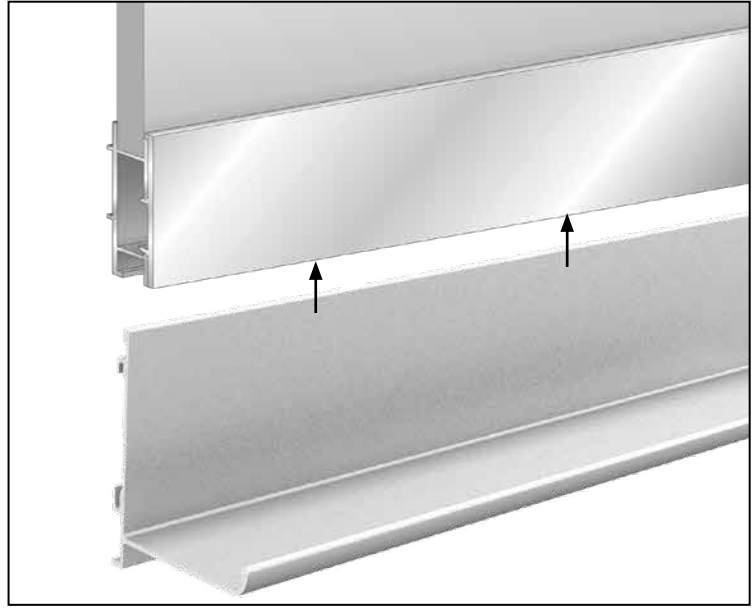

Press "Retainer Blocks" into place  
approximately every 20"-24"

Blocks should be "tight" in place.

**WARNING: Danger if improperly installed.** Installation must be done by a qualified professional.

For disposal, the components should be divided by type of material if possible. In any case, this product can be recycled at a community recycling center.

## Wall Mounted Penshelf

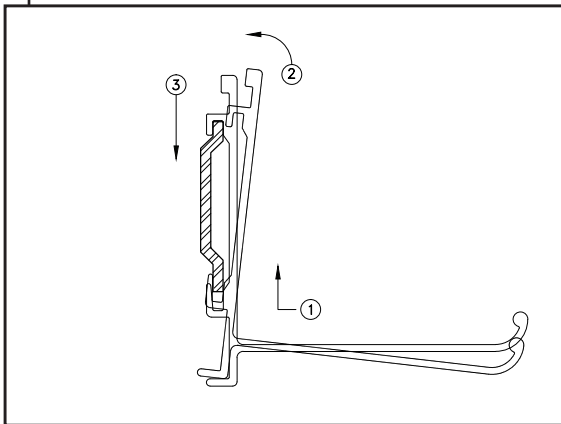
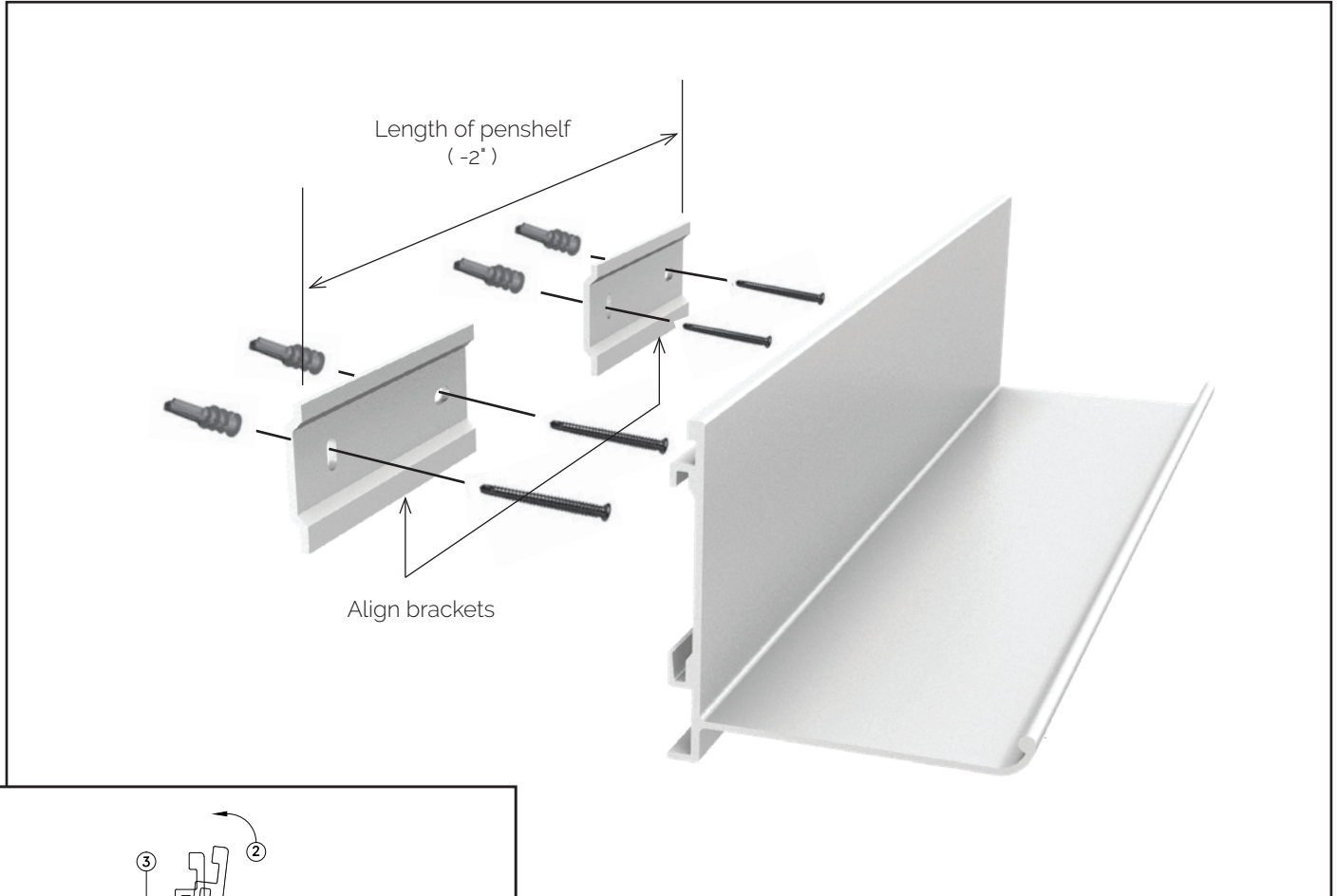

Items included with penshelf	
2	M-4 Brackets
4	#8 x 2" Self-drilling, Pan head screws
4	75lb. Drywall Anchors
*Penshelves longer than 32" will require additional brackets spaced approximately 18"-24" apart.	

1. Tilt penshelf down and hook bottom of bracket then lift.
2. Rotate top of penshelf over bracket
3. Push penshelf down onto bracket.

## Notes on Installation:

- Shims may be needed if the wall is not plumb and straight.
- Rubber bumpers may be needed behind boards to eliminate rattles or movement vibrations.
- Brackets must align with each other.
- Always screw into studs whenever possible.
- Outside screws on the bottom brackets should be within one inch (1") of each bracket end.

## Hanging Components:

- Check to make sure the track is clear of sheetrock dust and any other debris.
- If there is still a squeak, vibration or noise in the rail as the components slide, lubrication may be needed such as WD40, Vaseline or some other clean grease.
- Check to make sure when the brackets are installed, that the white pegs are at the top, outer corners and the wheels are at the bottom outer corners of the board.
- Check to make sure the top pegs are in the same track. Long pegs fit in the rear track closest to the wall. Short pegs fit in the front track.
- If two component boards contact each other and will not pass smoothly, check the height of both boards and try putting the long brackets on the tallest board to allow the shorter board to pass freely.

**WARNING: Danger if improperly installed.** Installation must be done by a qualified professional. Check the suitability of the wall and ceiling, and make sure that the fastening devices will withstand the loads.

For disposal, the components should be divided by type of material if possible. In any case, this product can be recycled at a community recycling center.